

ACCESSORIES FOR BRIDGE SAW MACHINES

MADE IN ITALY

BRIDGE AND JOB SITE SAW MACHINES

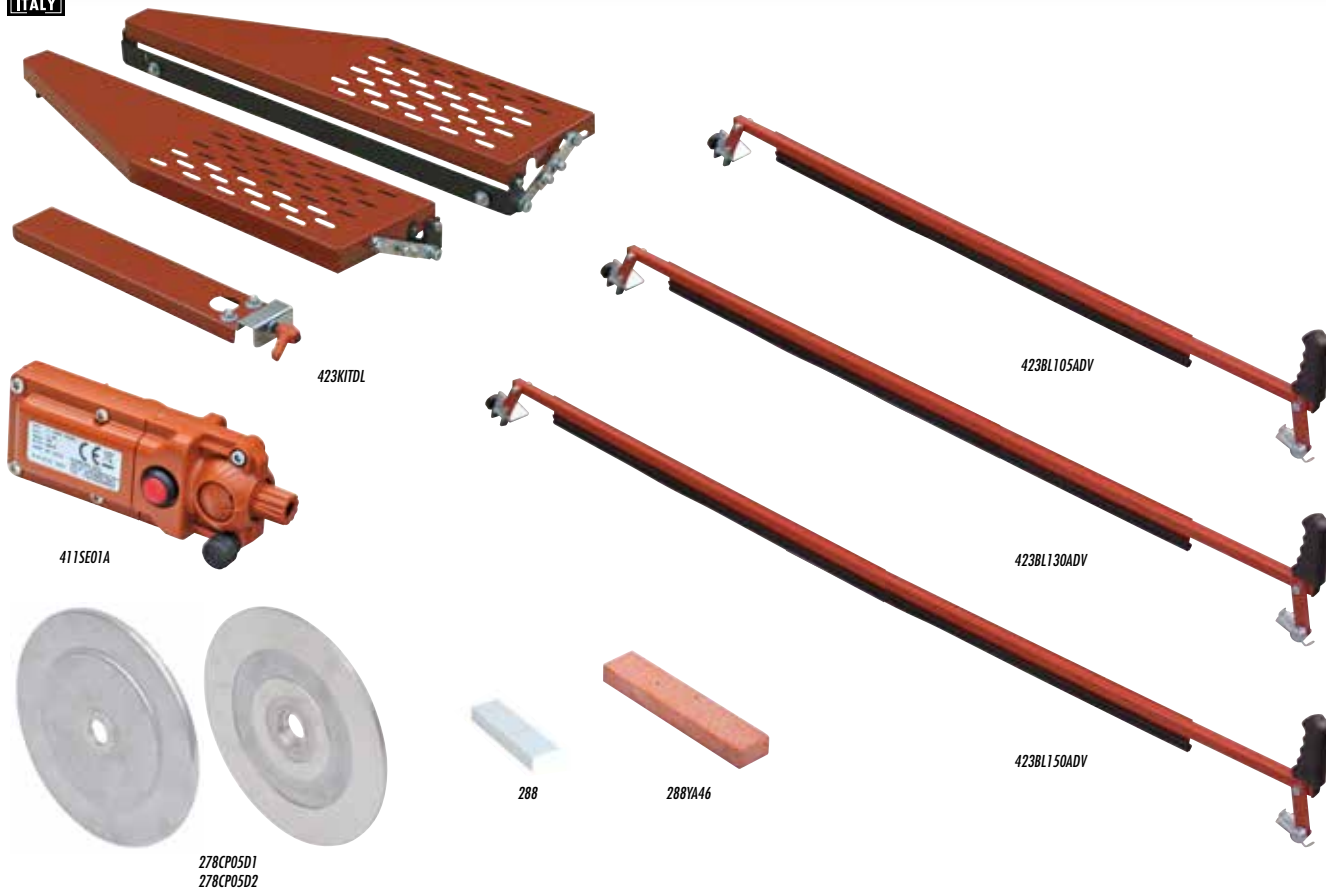

Part No.			Description				
423KITDL	8024648010476	1	Optional kit: folding extension tables and 90° left square	71x22xh 10 cm	28" x 8 5/8" x h 4"	5 Kg	11 lbs
423BL105ADV	8024648056757	1	Tile holder for Pikus 105 ADV, SMS 100, Zoe 105 ADV	117x24xh 20 cm	46" x 9 1/2" x h 7 7/8"	2,6 Kg	5.7 lbs
423BL130ADV	8024648066459	1	Tile holder for Pikus 130 ADV, SMS 125, Zoe 130 ADV	153x24xh 20 cm	60" x 9 1/2" x h 7 7/8"	3 Kg	6.6 lbs
423BL150ADV	8024648071187	1	Tile holder for SMS150 e Zoe 150 ADV	178x24xh 20 cm	70" x 9 1/2" x h 7 7/8"	3,5 Kg	7.7 lbs
411SE01A	8024648065254	1	Laser without stirrup	-	-	-	-
411SE A1	8024648070906	1	Laser with stirrup for ZOE Adv	-	-	-	-
411SE A2	8024648070913	1	Laser with stirrup for Pikus Adv	-	-	-	-
411SE A4	8024648070937	1	Laser with stirrup for SMS100,125 e 150	-	-	-	-
411SE A9	8024648005663	1	Laser with stirrup for SMS220 e SMS260	-	-	-	-
288	8024648004178	1	Dressing stone 30 x100xh 15 mm (1 3/16" x 4" x h 5/8")	-	-	-	-
288YA46	8024648079619	1	Dressing stone 45x230xh 25 mm (1 3/4" x 9 1/16" x h 1")	-	-	-	-
278CP05D1	8024648079060	2	Flanges (pair) Ø 200 mm (8") per Zoe ADV	-	-	-	-
278CP05D2	8024648079077	2	Flanges (pair) Ø 200 mm (8") per SMS e Mistral	-	-	-	-

Part no.	EXPLOIT			BOLT			MISTRAL			PIKUS			PIKUS ADV			SMS			LAB		ZOE ADV			SA	SA	SHERPA			
	70	90	120	90	120	150	90	120	150	75	85	105	130	100	125	150	220	260	270	330	400	85	105	130	150		80	09	
423KITDL	-	-	-	-	-	-	-	-	-	-	•	•	•	•	•	•	•	•	•	•	•	•	•	•	•	•	-	-	
423BL105ADV	-	-	-	-	-	-	-	-	-	-	-	-	•	•	•	•	•	•	•	•	•	•	•	•	•	•	-	-	
423BL130ADV	-	-	-	-	-	-	-	-	-	-	-	-	•	•	•	•	•	•	•	•	•	•	•	•	•	•	-	-	
423BL150ADV	-	-	-	-	-	-	-	-	-	-	-	-	•	•	•	•	•	•	•	•	•	•	•	•	•	•	-	-	
411SE01A	-	-	-	-	-	-	-	-	-	-	-	-	-	-	-	-	-	-	-	-	-	-	-	-	-	-	-	-	
411SE A1	-	-	-	-	-	-	-	-	-	-	-	-	-	-	-	-	-	-	-	-	-	-	•	•	•	•	-	-	
411SE A2	-	-	-	-	-	-	-	-	-	-	-	-	•	•	•	•	•	•	•	•	•	•	•	•	•	•	-	-	
411SE A4	-	-	-	-	-	-	-	-	-	-	-	-	•	•	•	•	•	•	•	•	•	•	•	•	•	•	-	-	
411SE A9	-	-	-	-	-	-	-	-	-	-	-	-	-	-	-	-	-	-	-	-	-	-	-	-	-	-	-	-	
288	•	•	•	•	•	•	•	•	•	•	•	•	•	•	•	•	•	•	•	•	•	•	•	•	•	•	•	•	•
288YA46	•	•	•	•	•	•	•	•	•	•	•	•	•	•	•	•	•	•	•	•	•	•	•	•	•	•	•	•	•
278CP05D1	-	-	-	-	-	-	-	-	-	-	-	-	-	-	-	-	-	-	-	-	-	-	•	•	•	•	-	-	
278CP05D2	-	-	-	-	-	-	-	-	-	-	-	-	-	•	•	•	•	•	•	•	•	•	•	•	•	•	-	-	





MADE IN ITALY



BRIDGE AND JOB SITE SAW MACHINES

Part No.	Barcode	Box Icon	Description	Box Icon	Weight	Weight
374RUS401	8024648090256	1	Self-standing 5 rollers side extension bench (length: 705mm; width: 506 mm)	80x60xh 20	31 1/2"x23 5/8"x h7 7/8"	20,7 Kg 45.6 lbs
191CL04A1	8024648080998	1	Telescopic set-square 90°/45° for Pikus Adv, SMS and Zoe Adv	80x33xh 21 cm	31 1/2"x13"xh 8 1/4"	9 Kg 19.8 lbs
192SQ03A	8024648014986	1	Sliding square 90°	42x7xh 5 cm	16 1/2"x2 3/4"xh 2"	900 gr 31.8 oz
192SQ07A	8024648053893	1	Left sliding square 45°/90°	29x22xh 7 cm	11 1/2"x8 5/8"xh 2 3/4"	900 gr 31.8 oz
191CL04A	8024648056122	1	Side square for Pikus ADV, Zoe ADV and SMS	81x45xh 13 cm	32"x17 3/4"xh 5"	4,5 Kg 10 lbs
191CL04A2	8024648088123	1	Side square for Exploit, Bolt, Mistral	100x45xh 12cm	39 3/8"x17 3/4"xh 4 3/4"	5,6 Kg 12.3 lbs
191CL05A	8024648058003	1	Side square for rolling side tables	68x66xh 10cm	27"x26"xh 4"	4,5 Kg 9.9 lbs
315CR02K	8024648089908	1	4 Wheels + handles kit for Exploit, Bolt and Mistral	33x33xh 10 cm	13"x13"xh 4"	3,3 Kg 7.3 lbs
263PE04A085	8024648019585	1	Water containment bars with nylon brushes for Pikus 85 Adv and Zoe 85 Adv	120xØ 12,5 cm	47 1/4"xØ 5"	3,6 Kg 7.9 lbs
263PE04A105	8024648019592	1	Water containment bars with nylon brushes for Pikus 105 Adv, SMS 100 and Zoe 105 Adv	120xØ 12,5 cm	47 1/4"xØ 5"	3,8 Kg 8.4 lbs
263PE04A130	8024648022233	1	Water containment bars with nylon brushes for Pikus 130 Adv, SMS 125 and Zoe 130 Adv	165xØ 12,5 cm	65"xØ 5"	4,6 Kg 10.1 lbs
263PE04A150	8024648022851	1	Water containment bars with nylon brushes for SMS 150 and Zoe 150 Adv	165xØ 12,5 cm	65"xØ 5"	4,9 Kg 10.8 lbs
263PE04A200	8024648026507	1	Water containment bars with nylon brushes for SMS 220	200xØ 12,5 cm	79"xØ 5"	6,6 Kg 14.6 lbs
263PE04A260	8050532001824	1	Water containment bars with nylon brushes for SMS 260	285xØ 12,5 cm	112"xØ 5"	7,6 Kg 16.8 lbs

Part no.	EXPLOIT			BOLT			MISTRAL			PIKUS			PIKUS ADV					SMS			LAB		ZOE ADV				SA 80	SA 09	SHERPA
	70	90	120	90	120	150	90	120	150	75	85	105	130	100	125	150	220	260	270	330	400	85	105	130	150	80	09		
374RUS401	•	•	•	•	•	•	•	•	•	•	•	•	•	•	•	•	•	•	•	•	•	•	•	•	•	•	•	•	•
191CL04A1	-	-	-	-	-	-	-	-	-	-	•	•	•	•	•	•	•	•	•	•	•	•	•	•	•	•	•	•	•
192SQ03A	•	•	•	•	•	•	•	•	•	•	•	•	•	•	•	•	•	•	•	•	•	•	•	•	•	•	•	•	•
192SQ07A	•	•	•	•	•	•	•	•	•	•	•	•	•	•	•	•	•	•	•	•	•	•	•	•	•	•	•	•	•
191CL04A	-	-	-	-	-	-	-	-	-	-	•	•	•	•	•	•	•	•	•	•	•	•	•	•	•	•	•	•	•
191CL04A2	-	•	•	•	•	•	•	•	•	•	•	•	•	•	•	•	•	•	•	•	•	•	•	•	•	•	•	•	•
191CL05A	-	•	•	•	•	•	•	•	•	•	•	•	•	•	•	•	•	•	•	•	•	•	•	•	•	•	•	•	•
315CR02K	•	•	•	•	•	•	•	•	•	•	•	•	•	•	•	•	•	•	•	•	•	•	•	•	•	•	•	•	•
263PE04A085	-	-	-	-	-	-	-	-	-	-	•	•	•	•	•	•	•	•	•	•	•	•	•	•	•	•	•	•	•
263PE04A105	-	-	-	-	-	-	-	-	-	-	•	•	•	•	•	•	•	•	•	•	•	•	•	•	•	•	•	•	•
263PE04A130	-	-	-	-	-	-	-	-	-	-	•	•	•	•	•	•	•	•	•	•	•	•	•	•	•	•	•	•	•
263PE04A150	-	-	-	-	-	-	-	-	-	-	•	•	•	•	•	•	•	•	•	•	•	•	•	•	•	•	•	•	•
263PE04A200	-	-	-	-	-	-	-	-	-	-	•	•	•	•	•	•	•	•	•	•	•	•	•	•	•	•	•	•	•
263PE04A260	-	-	-	-	-	-	-	-	-	-	•	•	•	•	•	•	•	•	•	•	•	•	•	•	•	•	•	•	•





DUAL SIDE BENCHES WITH COUNTERSQUARE AND ROLLERS/CUTTING WIDTH DIGITAL DISPLAY KIT



- They can be mounted on the wet saws between 125 cm (4.1') and 400 cm (13.1') models;
- The "main benches" are the ones to be directly bolted to the machine frame. Maximum distance between the countersquare and the line of cut: 161 cm (5.3');
- The "secondary benches" or more simply "extensions" (ACCESSORIES) must be mounted on the "main benches". They allow to reach 330 cm between the countersquare and the cutting guide;
- Both the "main benches" and the "secondary benches" can be equipped with specific digital displays to measure the cutting width (standard for LAB400);
- For all details and compatibility, we recommend to first review the chart here below and, eventually, contact Raimondi staff to verify the correct settings.

Part No.	Barcode	Box	Description	Box	Weight	Volume
374BRU 130	8050532019041	1	Kit of 2 "main benches" with countersquare. Maximum distance between the countersquare and the line of cut: 161 cm (5.3'). For Pikus 130, Zoe 130, Zoe 150, SMS 125, SMS 150	130x110xh 45 cm*	4.3'x3.6'xh 1.2**	46 Kg* 101.41 lbs*
374BRU 220	8050532019058	1	Kit of 2 "main benches" with countersquare. Maximum distance between the countersquare and the line of cut: 161 cm (5.3'). For SMS 220	130x110xh 55 cm* 230x12xh 5 cm*	4.3'x3.6'xh 1.8** 7.5'x0.4'xh 0.2**	82 Kg* 180.78 lbs*
374BRU 260	8050532020375	1	Kit of 2 "main benches" with countersquare. Maximum distance between the countersquare and the line of cut: 161 cm (5.3'). For SMS 260	130x110xh 55 cm* 270x12xh 5 cm*	4.3'x3.6'xh 1.8** 8.9'x0.4'xh 0.2**	86 Kg* 189.60 lbs*
374VISVESTD	8050532020429	1	Digital display kit for measurement of cutting width up to 1610 mm (5.3')	190x21xh 10 cm*	6.2'x0.7'xh 0.3**	11.2 Kg* 24.69 lbs*
374BRU 1F2	8050532020351	1	Kit of 2 "secondary benches". Without countersquare. For extending width of cut up to 330 cm - 10.8' (maximum distance between line of cut and countersquare: 3300 mm - 10.8'). For Pikus 130, Zoe 130, Zoe 150, SMS 125, SMS 150	130x110xh 45 cm*	4.3'x3.6'xh 1.2**	47 Kg* 103.62 lbs*
374BRU 2F2	8050532020368	1	Kit of 2 "secondary benches". Without countersquare. For extending width of cut up to 330 cm - 10.8' (maximum distance between line of cut and countersquare: 3300 mm - 10.8'). For SMS 220, SMS 260, LAB 270, LAB 330	130x110xh 55 cm*	4.3'x3.6'xh 1.8**	70 Kg* 154.32 lbs*
374BRU 400	8050532020382	1	Kit of 2 "secondary benches". Without countersquare. For extending width of cut up to 330 cm - 10.8' (maximum distance between line of cut and countersquare: 3300 mm - 10.8'). For LAB 400	130x110xh 55 cm* 190x8xh 7 cm*	4.3'x3.6'xh 1.8** 6.2'x0.3'xh 0.2**	75 Kg* 165.35 lbs*
374VISVEMAXI	8050532020412	1	Digital display kit for measurement of cutting width up to 3300 mm (10.8')	190x8xh 7 cm* 50x50xh 16 cm*	6.2'x0.3'xh 0.2** 1.6'x1.6'xh 0.5**	13.2 Kg* 29.1 lbs*

* Please note: weights and volumes data are indicative and can be confirmed only when the goods are ready for shipment.

COMPATIBILITY SCHEME DUAL SIDE BENCHES WITH COUNTERSQUARE AND ROLLERS/CUTTING WIDTH DIGITAL DISPLAY KIT

WHAT DO I WANT	WET SAW MODEL										
	PIKUS		ZOE			SMS			LAB		
	130	130	150	125	150	220	260	270	330	400	
Standard configuration	without bench					without bench		bench + square min 35 max 120 cm (min 1.14' max 3.93')	2 benches + countersquare min 0 max 161 cm (min 0' max 5.3')	2 benches + countersquare min 0 max 161 cm (min 0' max 5.3')	2 benches + countersquare min 0 max 161 cm (min 0' max 5.3') + digital display kit for measurement of cutting width up to 161 cm (5.3')
ACCESSORIES main bench/benches max width 161 cm (5.3')	art. 374BRU 130 bench + countersquare min 0 max 161 cm (min 0' max 5.3')					art. 374BRU 220 2 benches + countersquare min 0 max 161 cm (min 0' max 5.3')		art. 374BRU 260 2 benches + countersquare min 0 max 161 cm (min 0' max 5.3')	2 benches included in the machine	2 benches included in the machine	2 benches included in the machine
Digital display kit for measurement of cutting width up to 161 cm (5.3') (usable only in combination with "main" bench/benches)	art. 374VISVEST 2 digital displays kit for measurement of cutting width with profiles and magnetic stripes min 0 max 161 cm (min 0' max 5.3')										Digital display kit for measurement of cutting width included in the machine
ACCESSORIES secondary bench/benches (extensions) max width 330 cm (10.8') (usable only in combination with "main" bench/benches)	art. 374BRU 1F2 bench WITHOUT countersquare min 0 max 330 cm (min 0' max 10.8')					art. 374BRU 2F2 2 benches WITHOUT countersquare min 0 max 330 cm (min 0' max 10.8')			art. 374BRU 400 2 benches WITHOUT countersquare min 0 max 330 cm (min 0' max 10.8') + predisposition for the digital display to reach 330cm wide cuts.		
Digital display kit for measurement of cutting width up to 330 cm (10.8') (usable only in combination with "secondary" bench/benches - extensions)	art. 374VISVEMAXI 2 digital displays kit for measurement of cutting width with profiles and magnetic stripes min 0 max 330 cm (min 0' max 10.8')										Digital display kit for measurement of cutting width included in the machine

* For all details and compatibility, we recommend to first review the chart here below and, eventually, contact Raimondi staff to verify the correct settings.



MADE IN ITALY

BRIDGE AND JOB SITE SAW MACHINES



Part No.			Description
419AVBO=120	8024648090331	1	Wheel kit feed for Bolt 120
419AVBO=150	8024648090348	1	Wheel kit feed for Bolt 150
419AVMS=120	8024648090355	1	Wheel kit feed for Mistral 120/SMS 125
419AVMS=150	8024648090362	1	Wheel kit feed for Mistral 150
419AVMS=155	8024648022714	1	Wheel kit feed for SMS 150
419AVPK 085	8024648091543	1	Wheel kit feed for Pikus 85 Adv
419AVPK 105	8024648091550	1	Wheel kit feed for Pikus 105 Adv
419AVPK 130	8024648092755	1	Wheel kit feed for Pikus 130 Adv
419AVZO 085	8024648093233	1	Wheel kit feed for Zoe 85 Adv
419AVZO 105	8024648093240	1	Wheel kit feed for Zoe 105 Adv
419AVZO 130	8024648093257	1	Wheel kit feed for Zoe 130 Adv
419AVZO 150	8024648093264	1	Wheel kit feed for Zoe 150 Adv

Part no.	EXPLOIT			BOLT			MISTRAL			PIKUS				SMS				LAB			ZOE ADV				SA 80	SA 09	SHERPA
	70	90	120	90	120	150	90	120	150	75	85	105	130	100	125	150	220	260	270	330	400	85	105	130	150		
419AVBO=120	-	-	-	-	-	●	-	-	-	-	-	-	-	-	-	-	-	-	-	-	-	-	-	-	-	-	-
419AVBO=150	-	-	-	-	-	●	-	-	-	-	-	-	-	-	-	-	-	-	-	-	-	-	-	-	-	-	-
419AVMS=120	-	-	-	-	-	-	●	-	-	-	-	-	-	-	●	-	-	-	-	-	-	-	-	-	-	-	-
419AVMS=150	-	-	-	-	-	-	-	●	-	-	-	-	-	-	-	●	-	-	-	-	-	-	-	-	-	-	-
419AVMS=155	-	-	-	-	-	-	-	-	-	-	-	-	-	-	-	●	-	-	-	-	-	-	-	-	-	-	-
419AVPK 085	-	-	-	-	-	-	-	-	-	●	-	-	-	-	-	-	-	-	-	-	-	-	-	-	-	-	-
419AVPK 105	-	-	-	-	-	-	-	-	-	-	●	-	-	-	-	-	-	-	-	-	-	-	-	-	-	-	-
419AVPK 130	-	-	-	-	-	-	-	-	-	-	-	●	-	-	-	-	-	-	-	-	-	-	-	-	-	-	-
419AVZO 085	-	-	-	-	-	-	-	-	-	-	-	-	-	-	-	-	-	-	-	-	-	●	-	-	-	-	-
419AVZO 105	-	-	-	-	-	-	-	-	-	-	-	-	-	-	-	-	-	-	-	-	-	-	●	-	-	-	-
419AVZO 130	-	-	-	-	-	-	-	-	-	-	-	-	-	-	-	-	-	-	-	-	-	-	-	●	-	-	-
419AVZO 150	-	-	-	-	-	-	-	-	-	-	-	-	-	-	-	-	-	-	-	-	-	-	-	-	●	-	-

